

Harsh Industrial Environment Enclosure for Vision System Cameras

Protection against Dust, Dirt, Water & Oil Mist

Product features

- Built to provide protection for machine vision systems in an industrial environment
- Supports all standard IVS camera options
- Meets IP65 & NEMA 12 standards for ingress protection
- Anodised aluminium construction
- Comes standard with anti-reflection optical viewport
- Configurable gland for multiple cables
- Ready to mount on standard fixings



The IVS-SVP enclosure is a low cost anodised aluminium housing designed for standard IVS vision system requirements within harsh industrial environments. It provides protection of

your machine vision camera and optics from impact, dust, dirt, splashed water, oil mist and operator interference.

The enclosure is highly configurable

and can be adjusted easily to suit different optic and filter requirements. The front of the enclosure cover can easily be removed to provide the user with full access to the vision system camera and optics allowing changes to the focus and aperture settings. The IP65 cable gland at the rear of the enclosure is configurable to provide a watertight seal around one or more cables.

The standard IVS-SVP enclosure has telescopic adjustment to allow the lens to be adjusted close to the viewport to minimise reflections. The enclosure is designed to readily accommodate large diameter lenses if required.

Enclosure meets IP65/NEMA 12 standards when equipped with sealed viewport.

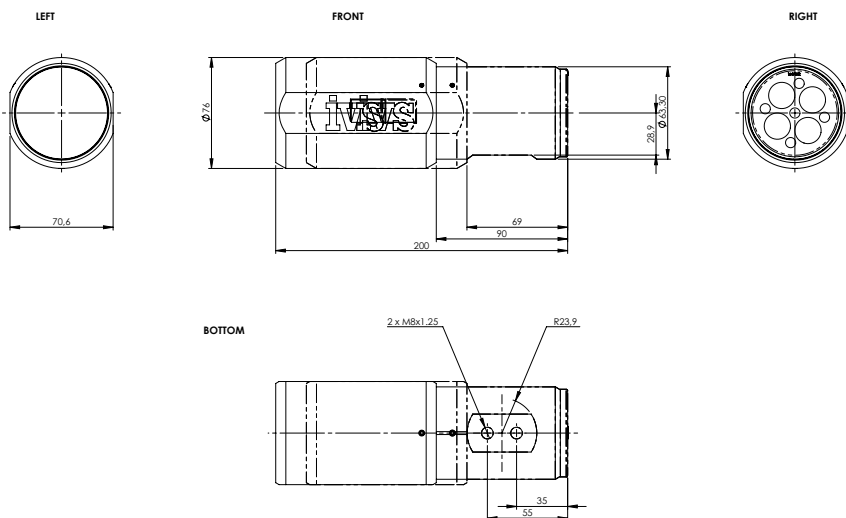

Industrial Vision Systems Ltd.
 Kingston Business Park, Kingston Bagpuize, Oxfordshire OX13 5FE, UK
 Tel: +44 (0) 1865 - 823322 Fax: +44 (0) 1865 - 823393
 Email: sales@industrialvision.co.uk

